

• *VB-FullAir*

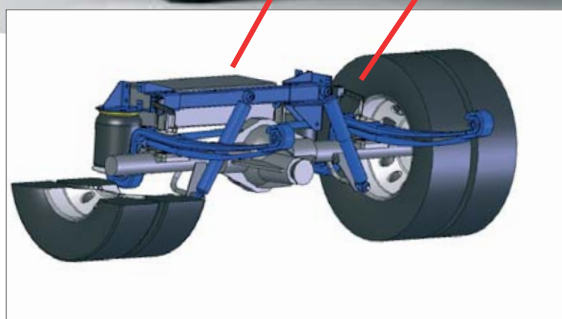

Iveco Daily 60-65C



with VB-FullAir 2-corner Airsuspension

www.vbairsuspension.com

Iveco Daily 60-65C with VB-FullAir 2-Corner Airsuspension

The Iveco Daily is available with rear axle air-suspension. The Daily is extremely suited for the use of air-suspension systems and our VB-FullAir-2C is available for new and used vehicles. This newly developed rear axle air suspension, from VB-Airsuspension, is available as an after-market option through the VB-Airsuspension dealers and Iveco network.

Market circumstances

The Iveco Daily will be used for a wide range of individual needs and market circumstances where air suspension is essential. For example: passenger transport, disabled persons transport, rescue vehicles, motorhomes, car transporters and for the transport of shock-sensitive products. For these and more usages, and individual needs, our VB-FullAir-2C is the right solution.

VB-FullAir-2C system

The VB-FullAir, a full-air rear-axle air-suspension, has an electronic system named VB-ASCU (VB-Air Suspension Control Unit), which automatically monitors and adjusts the height level of the vehicle. This constant monitoring and adjusting (independent of the load, in the longitudinal and lateral direction and relatively independent of centre gravity height) will automatically contribute to a safe vehicle behaviour and a better comfort. The vehicle may not be overloaded.



Changing height

The vehicle level can be changed manually with the standard hand-held when the vehicle stands still; therefore lowering of the chassis/load platform is one of the systems standard possibilities.

Software

The electronic part of the rear axle air suspension is compatible with the vehicle's main electrical system. Various software variants create the possibility to adapt the VB-FullAir-2C air-suspension to the specific use of the vehicle.

Advantages VB-FullAir-2C:

- Improved suspension comfort
- Constant ride height
- Improved road handling and stability
- Increased protection of vulnerable / sensitive goods
- Less impact for passengers
- Kneeling facility
- Less wear of tyres / brakes
- Environmentally friendlier, less CO2 emission



Supply and service

The air-suspension for the Iveco Daily can be supplied and serviced by VB-Airsuspension dealers and through the Iveco dealer organisation.

Technical specifications:	VB-FullAir 2C Rear 60-65C
Standard ride-height (Unloaded with original steel suspension)	788 mm
Ride height with VB-FullAir	710 mm
Highest position (0-5km/h)	+40 mm
Lowest position (0-5km/h)	-70 mm

All the measurements are in mm, measured above the centre-line of the rear axle on a standard chassis with tyresize 225/75R16 and a rear axle load of 3050kg. Therefore a tyre compression of 21 mm is included.

* Slight variations in measurements may occur due to tolerances in base vehicle.

For more information: info@vbairsuspension.com



© 01-2010